

PRISM: A COMPETITIVE SMALL MODULAR SODIUM-COOLED REACTOR

FISSION REACTORS

KEYWORDS: *spent/used nuclear fuel recycling, integral fast reactor, pyroprocessing*

BRIAN S. TRIPLETT,* ERIC P. LOEWEN, and BRETT J. DOOIES

GE Hitachi Nuclear Energy, 3901 Castle Hayne Road, Wilmington, North Carolina 28401

Received May 7, 2010

Accepted for Publication July 12, 2010

The Power Reactor Innovative Small Module (PRISM) designed by GE Hitachi Nuclear Energy is a small, modular, sodium-cooled fast reactor. The PRISM core is located in a pool-type containment vessel and is fueled with metallic fuel. Each PRISM produces 311 MW of electricity. The PRISM is inherently safe due to its negative power reactivity feedback, large in-vessel coolant inventory, passive heat removal systems, below-grade siting, and atmospheric reactor vessel operating pressure. In NUREG-1368, "Preapplication Safety Evaluation Report for the Power Reactor Innovative Small Module (PRISM) Liquid-Metal Reactor," the U.S. Nuclear Reg-

ulatory Commission stated that "On the basis of the review performed, the staff, with the ACRS [Advisory Committee on Reactor Safeguards] in agreement, concludes that no obvious impediments to licensing the PRISM design have been identified." PRISM is able to fission electrometallurgically recycled used nuclear fuel (UNF) from light water reactors as well as weapons-grade materials. PRISM, with the associated Nuclear Fuel Recycling Center, represents a safe, diversion resistant, commercially viable technology for recycling UNF with a small modular reactor.

I. INTRODUCTION

The concept of a liquid-metal-cooled reactor dates back to the genesis of nuclear energy. The first nuclear reactor to generate electricity was the liquid sodium-potassium-cooled fast reactor Experimental Breeder Reactor I (EBR-I) (Ref. 1). EBR-I's successor, the sodium-cooled fast reactor (SFR) Experimental Breeder Reactor II (EBR-II), operated successfully for more than 30 years, producing 20 MW of electricity via a sodium-steam power cycle.² Another SFR, S2G, supplied power to the United States' second nuclear submarine, USS *Seawolf* (SSN-575), for two years of intensive Cold War operations. The S2G plant was designed and built by General Electric (GE). In the 1980s and 1990s, GE led an industrial team that pursued commercial deployment of an SFR called Power Reactor Innovative Small Module (PRISM) as part of the U.S. Advanced Liquid Metal Reactor (ALMR) program administered by the U.S. Department of Energy.^{3,4}

In 2006, GE Hitachi Nuclear Energy (GEH) revitalized the PRISM engineering efforts as part of the

Department of Energy's Global Nuclear Energy Partnership⁵ (GNEP). Under GNEP, GEH proposed the Advanced Recycling Center (ARC) as a commercial solution for nuclear fuel recycling. The ARC is composed of the Nuclear Fuel Recycling Center (NFRC) and PRISM. Together these two technologies are used to produce electricity from recycled used nuclear fuel (UNF). The ARC consists of six PRISMs, each producing a net 311 MW of electricity. Two PRISMs are paired together in a power block to supply a 622-MW turbine-generator. The total ARC electrical output is 1866 MW. The fuel for the six PRISM reactors is supplied by a single NFRC, which is able to process light water reactor (LWR) UNF, PRISM UNF, and weapons-grade material into PRISM fuel.

At end of life, LWR UNF is composed of ~95% uranium, 1% transuranics, and 4% fission products.⁶ Many of these transuranic isotopes have long half-lives, which can create long-term engineering challenges for geologic disposal.⁷ The Integral Fast Reactor (IFR) concept proposes the recycling of the 96% of the fissionable material (uranium and transuranics) remaining in LWR UNF (Ref. 8). In this process, the uranium and transuranic material is continually recycled via electrometallurgical

*E-mail: Brian.Triplett@ge.com

processing (pyroprocessing) in a metal-fueled, sodium-cooled fast reactor. The ARC is the commercialization of this IFR concept. Through PRISM and the NFRC, the ARC is designed to generate electricity by fully recycling the usable fissionable material in UNF and reformed weapons-grade material.⁹

I.A. NFRC Overview

The NFRC uses the century-old electrometallurgical separations process employed by the aluminum industry for separating aluminum from alumina. This electrometallurgical process has been proved and deployed on a laboratory and engineering scale for nuclear materials by both Argonne National Laboratory (ANL) and Idaho National Laboratory¹⁰ (INL). Separations are accomplished by dissolving UNF in a molten salt bath and applying an electrical potential across the solution. The uranium and transuranics plate out on an anode and are subsequently removed from the solution.

With the NFRC process, nonproliferation concerns are alleviated by the intrinsic diversion resistance of the electrometallurgical process.^{9,11} All transuranics (Np, Pu, Am, Cm) are separated en masse in one step of the electrometallurgical process. These transuranics are continually recycled in the PRISM until they are fissioned completely.^{12,13}

The waste that results from the NFRC process is the genuine waste from nuclear processes, the fission prod-

ucts. The fission product waste requires a few hundred years of repository management time as opposed to the tens of thousands of years required for mixed-oxide reprocessed UNF and/or weapons-grade materials. The resulting metallic and ceramic waste forms from the ARC process are significantly more resistant to corrosion and are less susceptible to leaching into the environment than untreated UNF (Ref. 10).

I.B. PRISM Overview

The PRISM is a pool-type, metal-fueled, small modular SFR. PRISM employs passive safety, digital instrumentation and control, and modular fabrication techniques to expedite plant construction.¹⁴⁻¹⁷ The PRISM has a rated thermal power of 840 MW and an electrical output of 311 MW. Each PRISM has an intermediate sodium loop that exchanges heat between the primary sodium coolant from the core with water/steam in a sodium-water steam generator. The steam from the sodium-water steam generator feeds a conventional steam turbine. A diagram of the PRISM nuclear steam supply system (NSSS) is shown in Fig. 1.

Two PRISMs are paired to form one power block. A PRISM power block is shown in Fig. 2. The power block supplies steam for one 622-MW turbine-generator. The commercial PRISM plant achieves a high capacity factor by utilizing six reactor modules and their associated steam generating systems arranged in three identical power

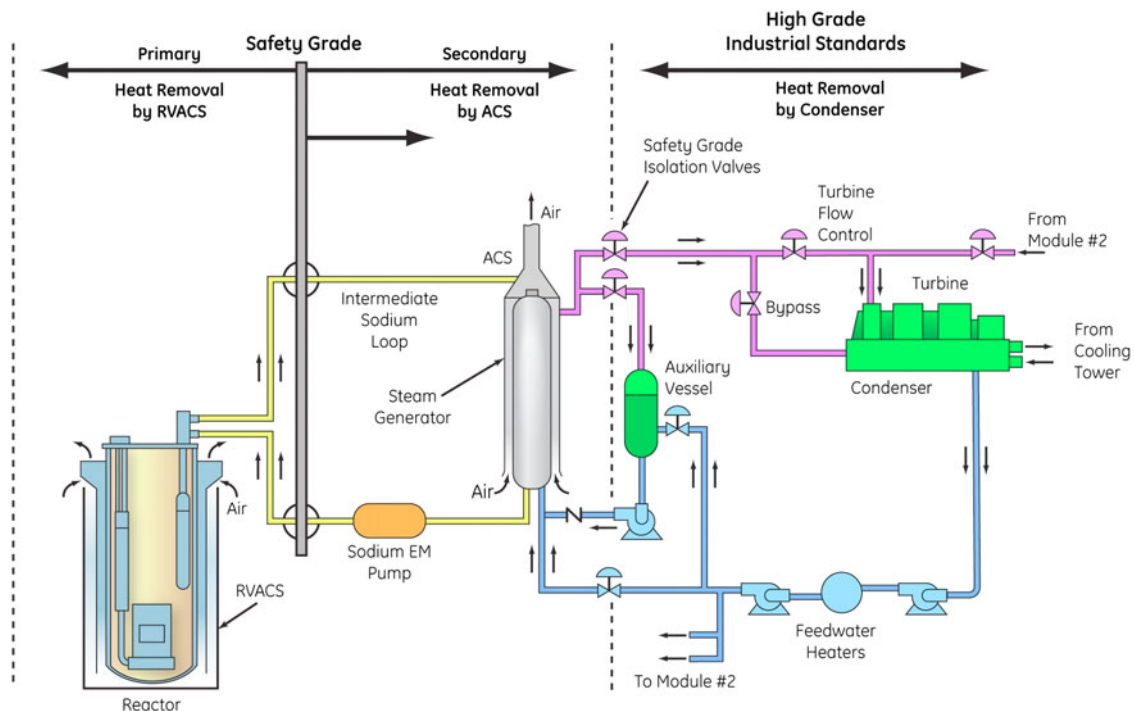

Fig. 1. PRISM NSSS.

1. Steam Generator
2. Reactor Vessel Auxiliary Cooling Sys
3. Refueling Enclosure Building
4. Steam Tunnel To Turbine
5. Reactor Protection System Modules
6. Seismic Isolation Bearing
7. Reactor Module
8. Primary Electromagnetic Pump
9. Reactor Core
10. Intermediate Heat Exchangers
11. Lower Containment Vessel
12. Upper Containment Building
13. Sodium Dump Tank
14. Intermediate Heat Transfer System
15. Steam Outlet Piping
16. Feedwater Return Piping

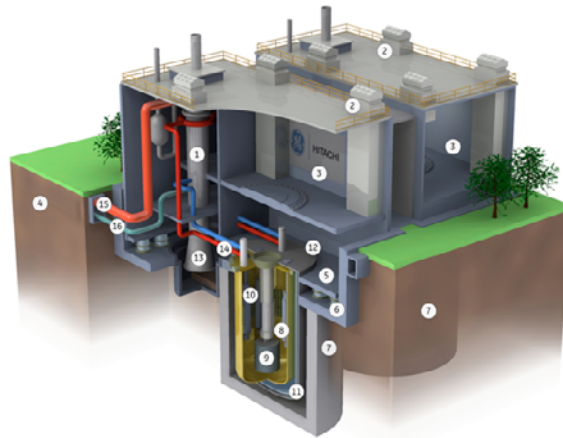

Fig. 2. PRISM power block.

blocks. An unplanned outage in one PRISM module or power block does not impact the plant electrical output as dramatically as it does in a large single-unit site.

Plant electrical output can be tailored to utility needs by the modular addition of power blocks. This modularity allows expansion from one power block to as many as desired by the utility on one site. The nominal ARC with three power blocks has a total electrical output of 1866 MW. The nominal system parameters of the reference ARC with three power blocks are summarized in Table I.

The remainder of this paper focuses on the PRISM component of the ARC. It presents a design overview and a summary of the commercialization plan for the ARC. Information concerning the balance of plant interfaces is provided as necessary to provide clarity of the reactor description.

II. DESCRIPTION OF PRISM

A PRISM module, pictured in Fig. 3, consists of the reactor vessel, reactor closure, containment vessel, internal structures, internal components, reactor module supports, and reactor core. The reactor vessel outer diameter can be fabricated in sizes of 6.6 m (Mod A) or 10 m (Mod B) depending on customer shipping constraints. The Mod A core has a smaller thermal output of 425 MW but is shippable by rail, whereas the Mod B has an 840-MW thermal output and is shippable by barge and overland transportation. The power levels of the associated cores are primarily limited by the shutdown heat removal capabilities of the passive safety systems. A detailed discussion of the cost-benefit of reactor vessel/thermal power sizing is presented in Ref. 18. Mod B vessels are considered as the nominal configuration for the purposes of this work.

TABLE I
Nominal ARC Parameters

Overall plant	
Electrical output	1866 MW
Thermal efficiency	37%
Number of power blocks (per plant)	3
Number of reactor modules (per plant)	6
Power block	
Number of reactor modules (per block)	2
Net electrical output	622 MW
Number of steam generators	2
Steam generator type	Helical coil
Steam cycle	Superheated steam
Turbine type	3600 rpm, tandem compound, four flow
Turbine throttle conditions	14.7 MPa (2135 psia)/452°C (846°F)
Main steam flow	2738 Mg/h (6.024 × 10 ⁶ lb/h)
Feedwater temperature	216°C (420°F)
Reactor module	
Thermal power	840 MW
Primary sodium inlet/outlet temperature	360°C (680°F)/499°C (930°F)
Primary sodium flow rate	5.4 m ³ /s (86 000 gal/min)
Intermediate sodium inlet/outlet temperature	326°C (619°F)/477°C (890°F)
Intermediate sodium flow rate	5.1 m ³ /s (80 180 gal/min)

II.A. Containment Vessel and Reactor Internals

The outermost structure of the reactor module is the containment vessel. The containment vessel contains the reactor vessel and internals and is sealed with a reactor closure. The inside of the reactor vessel is filled with liquid sodium and a helium cover gas. The helium cover

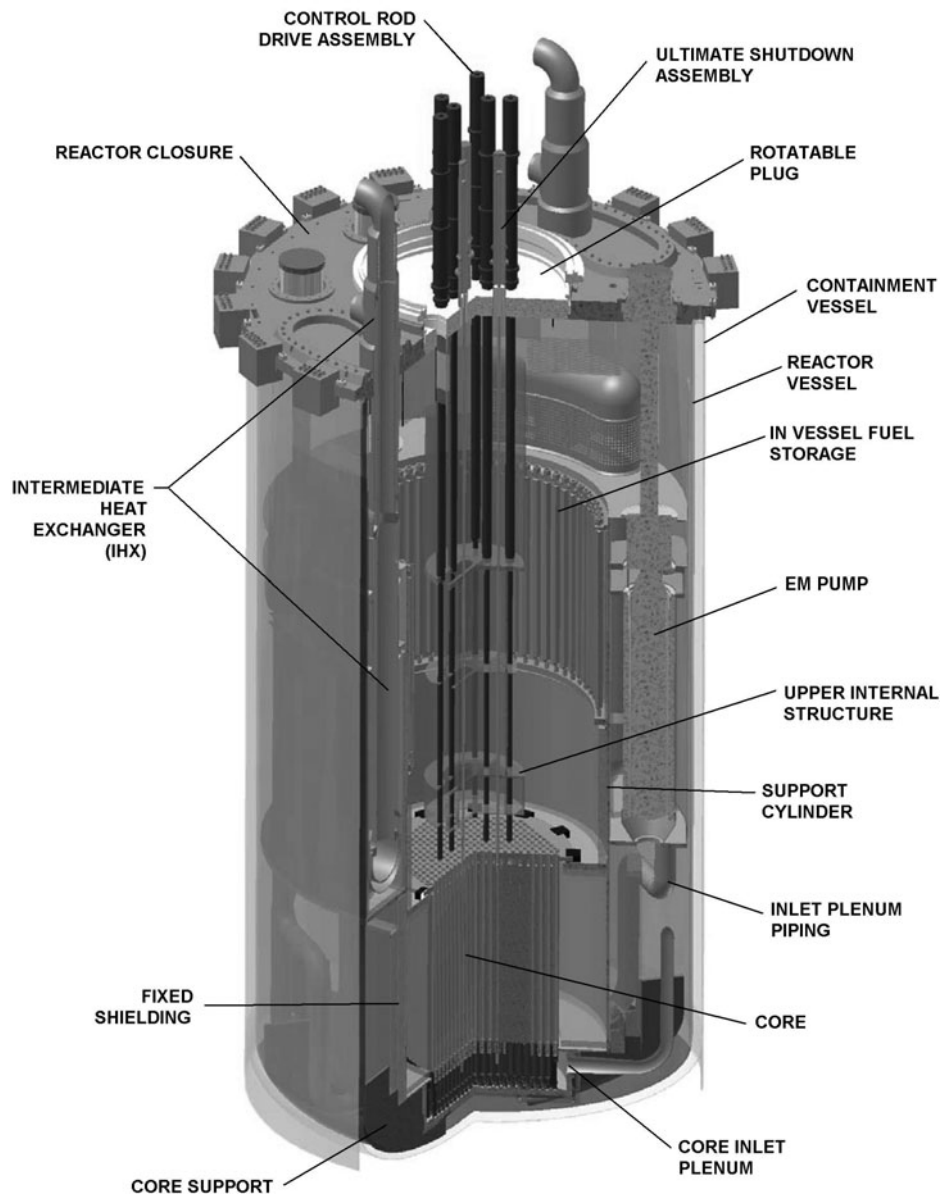

Fig. 3. PRISM reactor module.

gas is at approximately atmospheric pressure at normal power conditions. A 20-cm gap between the containment vessel and the reactor vessel is filled with argon at a pressure slightly above the reactor cover gas pressure.¹⁶

The reactor closure is a single plate with a rotatable plug and penetrations for the reactor equipment, primary sodium cleanup, and cover gas service lines. Primary sodium cleanup is accomplished during reactor shutdown by a single cold-trap system shared by each power block. There are no penetrations in the reactor vessel or

the containment vessel. The closure penetrations are shown in Fig. 4. The reactor vessel is butt-welded to a lip on the underside of the closure. The containment vessel is bolted to the closure and sealed by welding. The reactor module is supported entirely from the closure by hold-down brackets. The closure-containment vessel connection and support detail are shown in Fig. 5.

The reactor core support consists of a redundant beam structure on the bottom and the sides of the reactor vessel. A core barrel and support cylinder extends

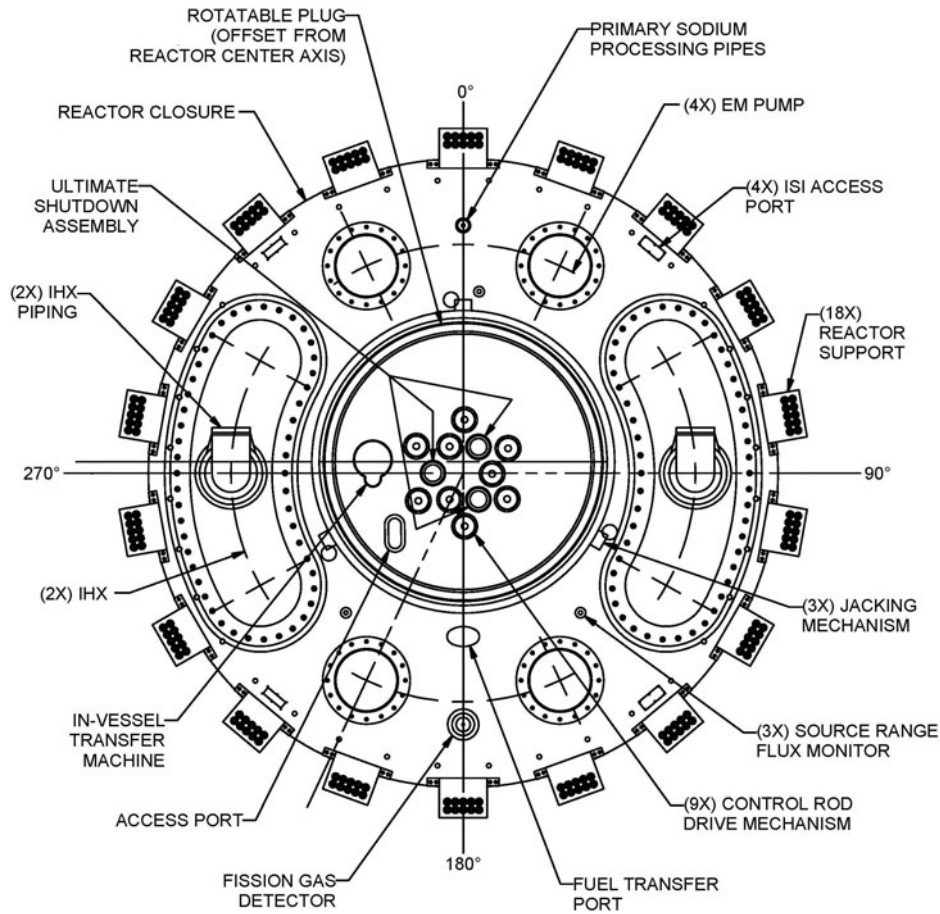

Fig. 4. Reactor closure penetrations.

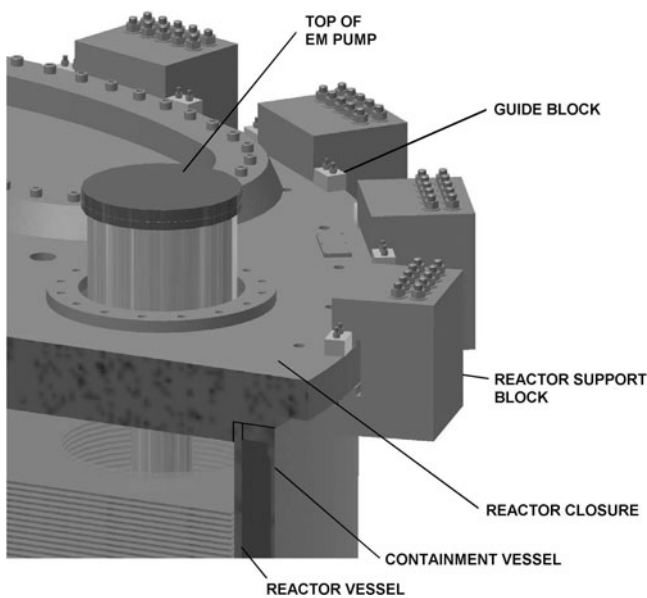

Fig. 5. Reactor closure support detail.

from the inlet plenum to above the core to contain the core and storage racks for temporary storage of off-loaded fuel assemblies. The internal core structure is shown in Fig. 6.

Two intermediate heat exchangers (IHX) and four electromagnetic (EM) primary pumps are suspended in the reactor vessel by the reactor closure. Primary control rod drives, ultimate shutdown rod drives, in-vessel instrumentation, and an in-vessel transfer machine (IVTM) for fuel handling are suspended from the rotatable plug in the closure.¹⁶ The reactor closure with major equipment is shown in Fig. 7.

II.B. Reactor Core

PRISM uses a metallic fuel for compatibility with the coolant, its desirable thermomechanical properties, and ease of fabrication.^{19,20} The PRISM core has a heterogeneous layout consisting of multiple assembly types. These types include fuel, blanket, control, reflector, and shield assemblies. The fuel composition and assembly

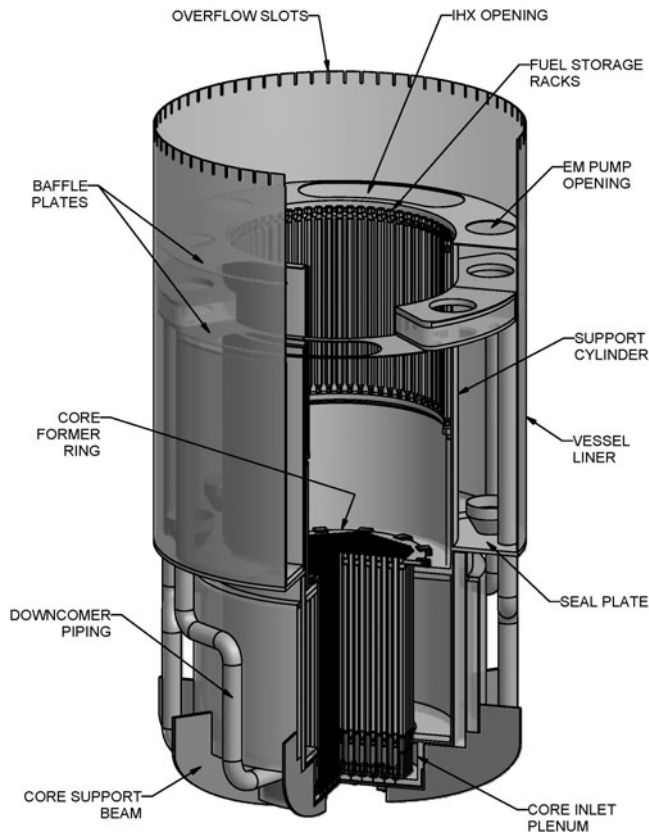

Fig. 6. Reactor vessel internal structure.

configuration varies based on the core mission. Possible core missions include low conversion ratio (UNF actinide recycle), unity conversion ratio (breakeven), high conversion ratio (breeder), or weapons material consumption.^{21,22}

For the UNF recycling core mission, the fuel is composed of a uranium-transuranic-zirconium alloy (U-TRU-Zr) with two fuel zones. The assembly configuration for this core mission is shown in Fig. 8. A comparison of the various core configurations is displayed in Table II and the number of assemblies for each mission is given in Table III.

The metallic fuel for PRISM is fabricated in the NFRC by performing electrometallurgical separations of UNF (also known as pyroprocessing), distilling away any volatile elements and residual molten salt, and then injection casting the molten fuel material into fuel slugs. Details of metal fuel fabrication and usage in sodium fast reactors are given in Refs. 23 through 26. These fuel slugs are loaded into cylindrical rods and backfilled with sodium. This sodium bond improves heat transfer between the fuel and the cladding prior to fuel-cladding contact. Each fuel rod is then filled with a small amount of argon-neon tag gas and sealed through welding. The tag gas provides internal pressure in the rod and allows for the tracing of fuel failures to a specific fuel assembly. A large gas plenum volume ~ 1.5 times the length of the active core is included in each pin to accommodate fission gas release during operation. A typical fuel rod is shown in Fig. 9.

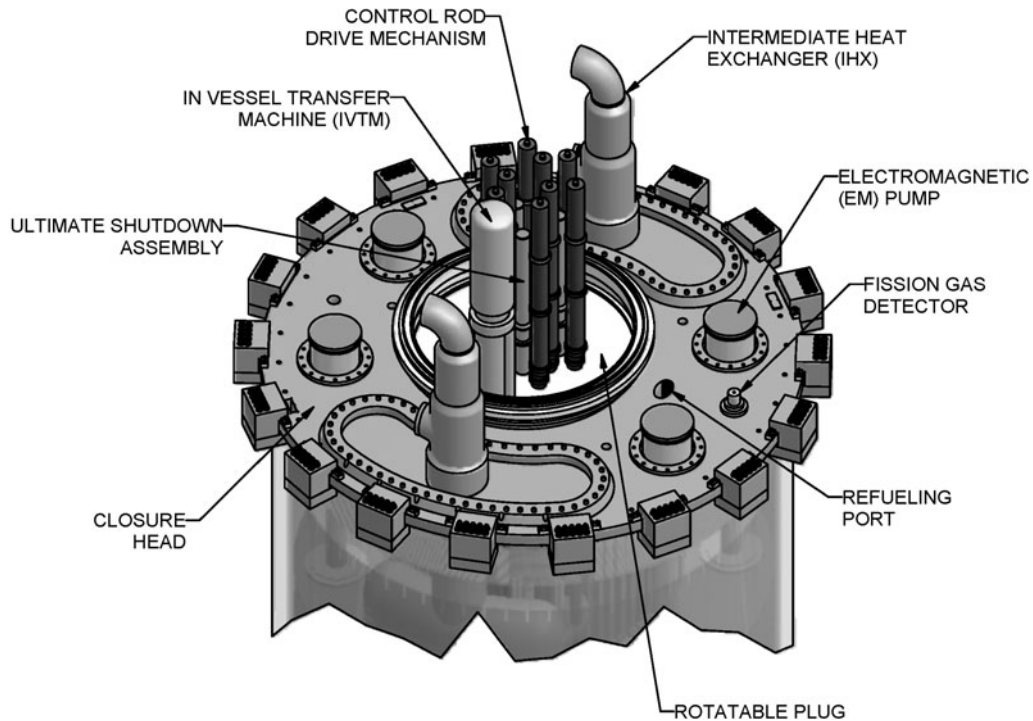

Fig. 7. Reactor closure with equipment shown.

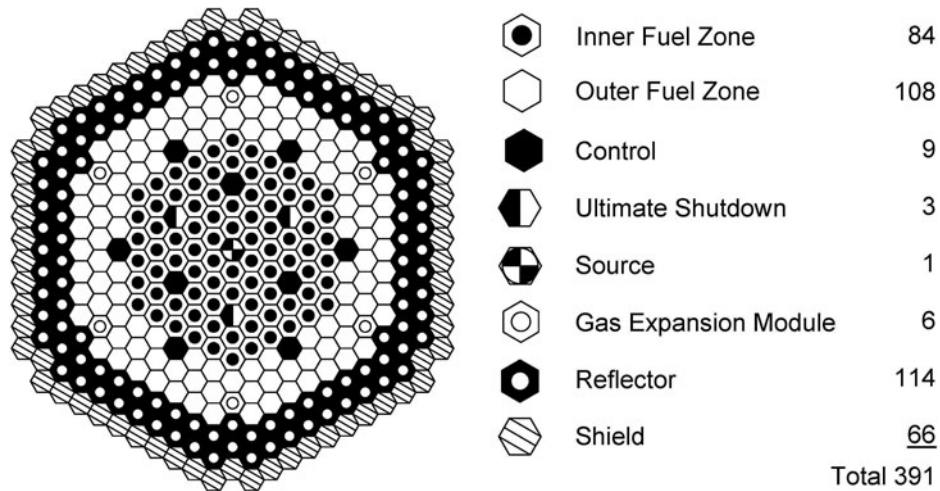

Fig. 8. Fuel assembly layout for UNF recycle core.

TABLE II
Nominal PRISM Fuel Cycle Parameters

Parameter	Core Configuration			
	UNF Recycle	Breakeven	Breeder	Weapons Pu Consumption
Thermal power (MW)	840	840	840	840
Conversion ratio	0.72	1.06	1.23	1.00
Cycle length (months)	12	23	23	26
Reload batch fraction (driver/blanket)	0.25	0.33/0.25	0.33/0.25	0.33/0.25
Fissile Pu ^a content ^b (wt%)	11.3 inner ^c 13.5 outer ^c	15.8	15.6	17.2
Total transuranics content ^b (wt%)	18.9 inner ^c 22.7 outer ^c	21.1	20.9	18.3
Average discharge burnup ^b (MWd/kg HM)	87.51	106.3	103.2	106.3
Peak discharge burnup ^b (MWd/kg HM)	122.7	147.3	144.0	146.4
Net fissile Pu production (kg/yr)	(71.9)	16.8	57.3	1.38
Active core height (cm)	66.0	106.7	106.7	106.7

^aFissile Pu includes ²³⁹Pu and ²⁴¹Pu.

^bDriver fuel. Blanket fuel (if present) may differ.

^cThe UNF recycle core has two fuel zones, inner and outer, with different transuranics contents.

The cladding chosen for the fuel rods and much of the internal structure is the stainless steel alloy HT9 (Ref. 27). HT9 has been chosen for many fast neutron applications due to its resistance to radiation damage and strength.^{28,29}

PRISM fuel rods are bundled together into a hexagonal lattice. A fuel assembly schematic is shown in Fig. 10. Rod spacing is maintained by a spiral wire wrap around each rod. Each fuel assembly includes a hexagonal duct around the fuel pins to maintain coolant flow around the pins. Flow orificing is employed due to the different heat

generation rates among fuel, blanket, reflector, and shield assemblies.

II.C. Reactivity Control

Reactivity control for normal startup operation, load following, and shutdown is accomplished with control rods. Each control unit consists of a drive mechanism, a driveline, and a control assembly. A stepping motor, controlled by the plant control system, actuates a lead screw to insert and withdraw the B₄C absorber. The nine control

TABLE III
PRISM Assembly Count

Assembly Type	Core Configuration			
	UNF Recycle	Breakeven	Breeder	Weapons Pu Consumption
Driver fuel (inner + outer)	192	108	108	108
Internal blanket	—	42	42	42
Radial blanket	—	42	42	42
Control	9	9	9	9
Ultimate shutdown	3	3	3	3
Neutron source	1	1	1	1
Gas expansion module	6	6	6	6
Reflector	114	114	114	114
Shield	66	66	66	66
Total	391	391	391	391

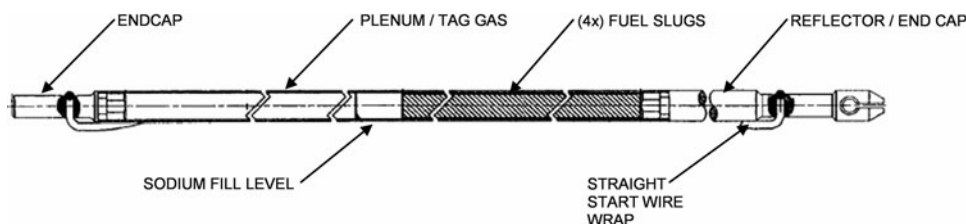

Fig. 9. PRISM fuel rod.

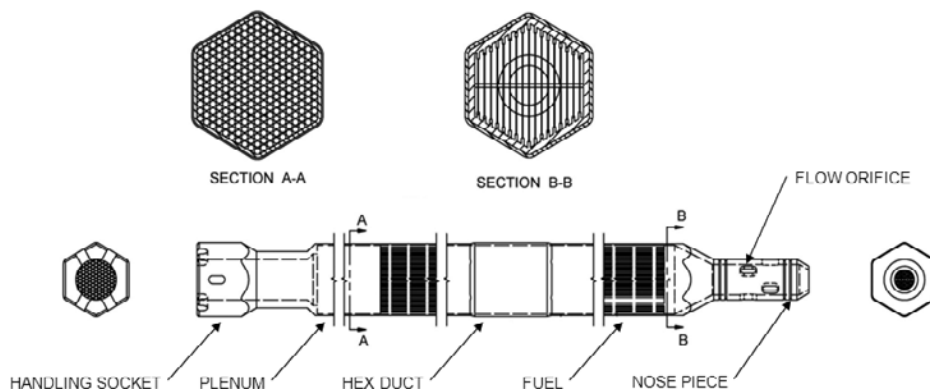

Fig. 10. PRISM fuel assembly.

rods have scram diversity and shutdown redundancy. A schematic of a control assembly is shown in Fig. 11.

The primary shutdown system is backed up by an ultimate shutdown system. These control rods use magnetic latches, which can be actuated by either the reactor protection system or automatically when the latch tem-

perature exceeds the magnetic curie point temperature of the latch.

Both shutdown systems are backed up by the inherent negative power reactivity feedback of the reactor core. This inherently negative reactivity feedback brings the core to a safe, stable power state following accidents.

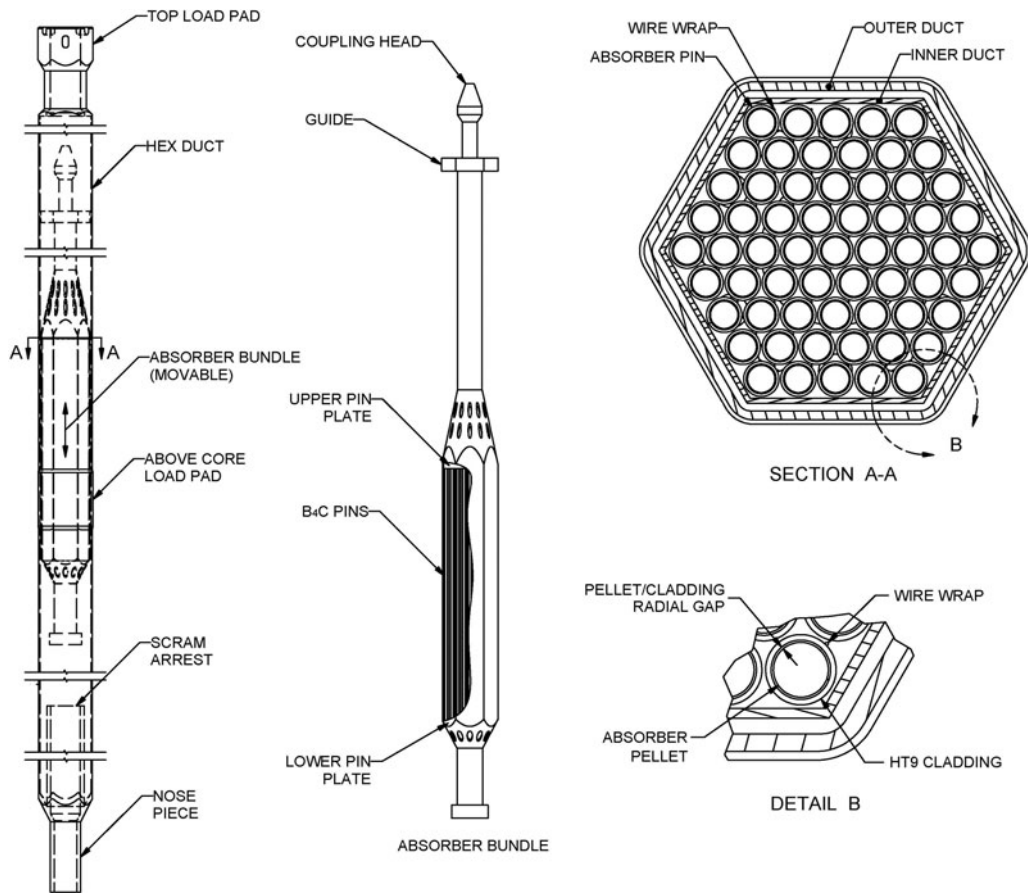

Fig. 11. PRISM control assembly.

PRISM has this capability for accommodating the following severe, but extremely unlikely, accidents³⁰⁻³⁴:

1. inadvertent withdrawal of all control rods without automatic scram or manual actuation (unprotected transient overpower)
2. loss of all cooling by the intermediate heat transport system without scram (unprotected loss of cooling)
3. loss of primary pump power and loss of all cooling by the intermediate heat transport loop without scram (unprotected loss of flow/loss of cooling).

These accident scenarios were evaluated experimentally by ANL in EBR-II (Refs. 35 through 38) and at the TREAT facility.³⁹ These tests empirically demonstrated the safety of a pool-type, metal-fueled SFR like PRISM.

II.D. Primary Heat Transport System

Nuclear heat is removed from the reactor core by the primary heat transport system (PHTS). The PHTS is entirely contained within the reactor vessel and is com-

posed of the reactor core, the hot pool, the tube side of the IHX, the cold pool, the EM pumps, the pump discharge piping, and the core inlet plenum. Within each reactor module, four EM pumps circulate the primary sodium through two IHXs. The primary coolant flow path is shown in Fig. 12.

II.E. Primary EM Pumps

PRISM has four submerged EM pumps to provide primary sodium circulation within the reactor vessel. The pumps are inserted through penetrations in the reactor closure. These pumps have no moving parts and no external shaft penetrations. The pumps draw cold-pool sodium from an inlet plenum beneath the pump. Within the pump, the sodium enters the tapered inlet section of the pump duct. The sodium is discharged from the top of the pump and is passed radially outward into the pump outlet plenum from which it flows to the core inlet plenum.

II.F. Intermediate Heat Transport System

The intermediate heat transport system (IHTS) consists of piping and components required to transport the

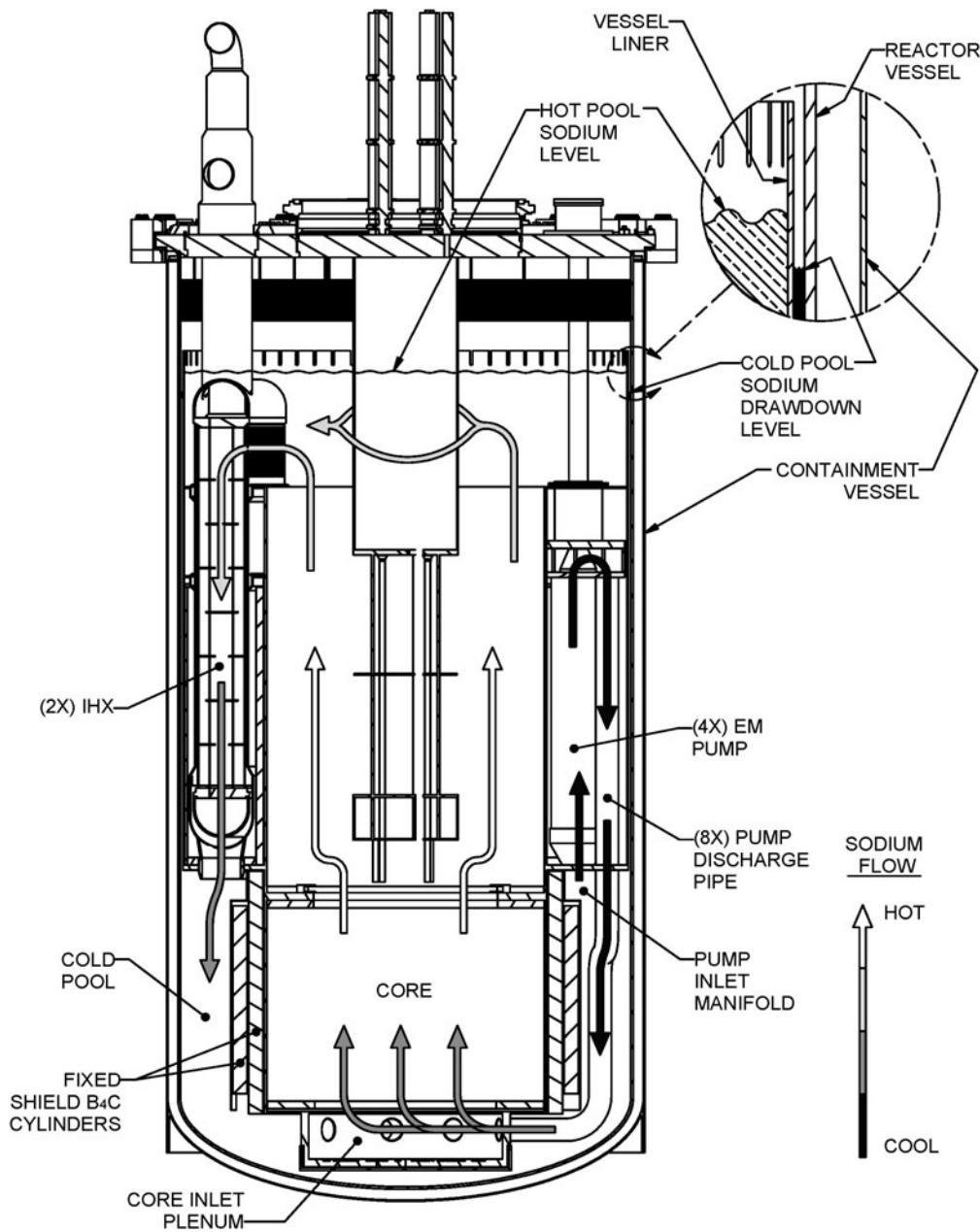

Fig. 12. Primary heat transport system.

reactor heat from the PHTS to the steam generator system (SGS). The IHTS is a closed-loop system with an expansion plenum in the steam generator top head and an argon cover gas space to accommodate thermally induced system volume changes. Intermediate sodium is circulated through the shell side of the IHX and the shell side of the steam generator by two EM pumps, each located in the cold leg of the loop in the steam generator facility. These secondary sodium pumps are similar in design to those employed in the primary system. Guard pipes surrounding the IHTS pipes prevent secondary sodium leakage into the head access area (HAA).

Hot-leg sodium is transported in separate stainless steel pipes from the two IHXs to the steam generator top head through vertical inlet nozzles. The cold-leg piping returns the sodium to the IHX. The IHX flow path is shown in Fig. 13.

A sodium leak detection system provides early warning of any sodium-to-air leaks from the IHTS. In the event of a steam generator (SG) tube leak, the sodium-water reaction pressure relief system (SWRPRS) provides overpressure protection of the IHTS and IHXs. The SWRPRS consists of a safety-grade rupture disk, a separator tank, a vent stack, and a hydrogen igniter. To

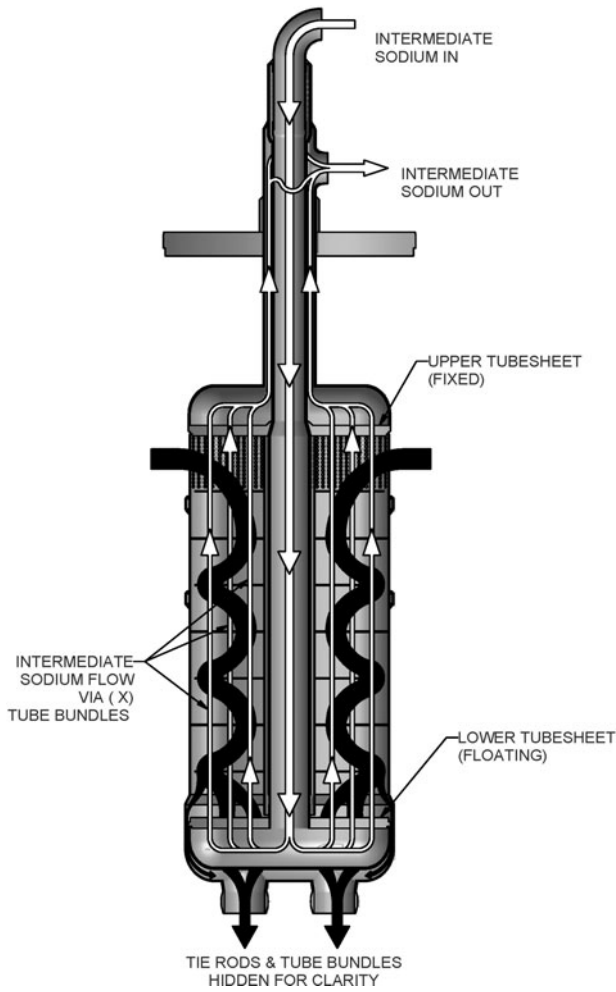

Fig. 13. Intermediate heat exchanger.

separate the reactants, the SWRPRS initiates the water-side isolation and blowdown of the SGS and the purge of the SG tubes with nitrogen.¹⁶

II.G. Steam Generator System

Each reactor has one associated SG for the production of superheated steam. The SGS is composed of the SG, the startup recirculation tank and pump, a leak detection subsystem, and the SG isolation valves. The two SGSs in a power block are headered together to feed one turbine-generator. The SG is a vertically oriented, helical coil, sodium-to-water counterflow heat exchanger designed to generate superheated steam. Sodium flows down the shell side of the SG, while feedwater enters from the bottom. As the water flows upward it is converted into superheated steam.⁴⁰

II.H. Decay Heat Removal System

During reactor shutdown heat is removed by the turbine condenser using the turbine bypass. An auxiliary

cooling system (ACS) is provided as an alternative method for shutdown decay heat removal during maintenance or repair operations. The ACS uses natural or forced circulation of atmospheric air to remove heat as the air flows past the shell side of the SG. The ACS consists of an insulated shroud around the SG shell with an air intake at the bottom through the annulus and an isolation damper located above the SG building. Natural circulation is initiated by opening the exhaust damper.⁴¹ The ACS is shown in Fig. 14.

The reactor vessel auxiliary cooling system (RVACS) has the capability to maintain reactor temperatures well below design limits using natural circulation. The RVACS supplements the ACS in the removal of decay heat. The RVACS uses natural air convection to remove heat from the reactor module. Atmospheric air is drawn into the reactor building and flows over the outside of the containment vessel. The warm air then returns to the stack and is exhausted. Since it is a completely passive system, the RVACS is always operating and removing heat from the reactor module. The RVACS layout is shown in Fig. 15.

In the highly unlikely event that the IHTS becomes completely unavailable, the safety-related RVACS will

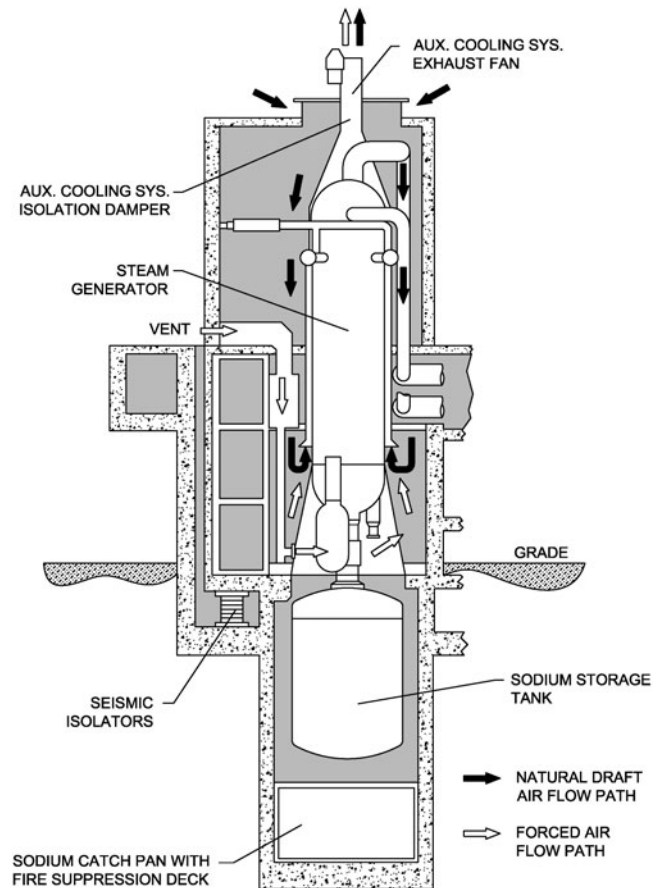

Fig. 14. Auxiliary cooling system.

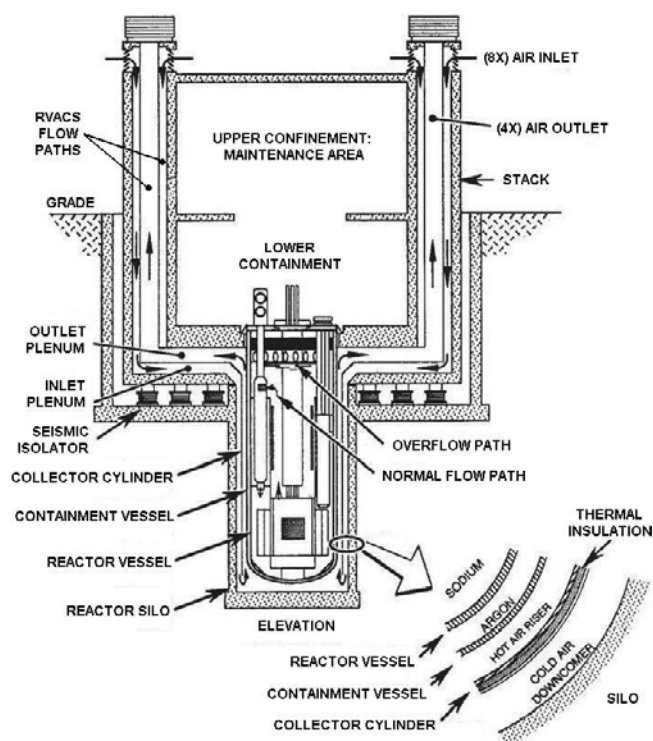

Fig. 15. Reactor vessel auxiliary cooling system.

passively remove decay heat from the reactor vessel. At the beginning of this loss of heat sink transient, the temperatures of the reactor sodium and reactor vessel will rise. This increased temperature will increase the radiant heat transfer across the argon gap to the containment vessel. The heat is then transferred from the containment vessel to the upwardly flowing atmospheric air around the vessel. The RVACS system protects the reactor containment vessel from incurring significant damage during severe transients such as the loss of heat sink.⁴²

II.I. Reactor Refueling System

Reactor refueling occurs in intervals of between 12 and 24 months, depending on the fuel cycle operation and mission. Fuel assemblies are allowed to decay in in-vessel, ex-core storage positions for one cycle before they are removed and transferred to the NFRC for processing. Within the reactor vessel, assemblies are moved between the core, storage racks, and a transfer station below the transfer port by the IVTM. The fuel storage racks can be seen in Figs. 3 and 6.

An adapter is attached to the transfer port in the reactor closure during refueling to provide the necessary system isolation. An ex-vessel transfer machine (EVTM) is positioned and a leak tight connection is made to the adapter. The EVTM is used to exchange spent fuel and other core assemblies in the reactor with new assemblies

from the transfer cask. The transfer cask is then returned to the NFRC, where the spent fuel will be cleaned, inspected, and stored in an air-cooled storage rack.¹⁶

II.J. Containment

The function of the PRISM containment is to protect the public from any accidental release of radioactivity from the reactor. Along with the fuel cladding and the primary coolant boundary, it is one of the three barriers used to achieve this protection. The containment consists of the containment vessel surrounding the reactor vessel and a lower containment over the reactor closure.

The containment vessel is a stainless steel vessel surrounding the entire reactor vessel. It has no penetrations and is designed to be leak tight. There is a 20-cm annulus between the containment and the reactor vessel. In the unlikely event of a reactor vessel leak, the containment is sized to retain all of the primary sodium while keeping the core, stored spent fuel, and heat exchanger inlets covered with sodium.⁴¹

The lower containment is located above the reactor closure head. It is designed to provide a barrier in the event of a closure breach during a hypothetical core disruptive accident.⁴³ The lower containment volume is defined by the HAA above the reactor deck. Reactor containment can be seen in Fig. 15 along with RVACS.

II.K. Seismic Isolation

Seismic isolation was adopted in the PRISM design to enhance seismic safety margins and to allow the application of a standard nuclear island design to sites with different soil and seismic characteristics. The entire NSSS and all safety systems are located on a common platform that is supported by seismic isolation bearings. The seismic isolation bearings provide a horizontally flexible element between the basemat and the nuclear island platform to absorb seismic shocks by allowing the superstructure to displace rather than remain rigid. Compared to a non-isolated system, the isolation system reduces the horizontal seismic accelerations that are transmitted to the reactor module by a factor of 3. Equally important, the facilities that are seismically isolated can be adapted for a large range of sites by adjusting the seismic isolator characteristics.^{44,45}

III. PRISM COMMERCIALIZATION

The ARC, consisting of six PRISMs and an NFRC, constitutes a commercially viable facility capable of positive cash flows and return on investment. An independent financial analysis of the estimated capital cost of an *N*'th-of-a-kind ARC facility found it to be competitive with advanced LWRs (Ref. 46). This study showed that once initial licensing and design are complete, the

reference ARC facility is capable of commercial operation without the need for government subsidy or assistance. These attractive economics are made possible by the income from the 1866 MW of electricity generated by the ARC and low costs derived from PRISM's modularization and passive systems.^{46–49}

III.A. Advantages of the Modular Approach

GEH has performed many trade-off studies investigating the advantages of modular SFR plants compared to large monolithic plants.⁵⁰ These assessments have led to the conclusion that the small modular concept has several key features that make it more competitive. These advantages are:

1. Generating capacity can be added in stages, allowing more flexible construction arrangements and supply growth in line with demand.
2. Competitive cost is not achieved by scaling up the size of the modules but rather by allowing for repeatable factory fabrication.
3. Factory fabrication provides improved quality, reduced cost, and shortened construction times.
4. Simplified passive safety systems due to lower thermal power improve overall plant safety and reduce system costs.
5. Class 1-E safety-related emergency power requirements⁵¹ can be met by batteries, eliminating the need for costly diesel or natural gas generators.
6. The independent operation of each NSSS reduces the grid impact of a reactor scram event.

The passively safe features of the plant design are achieved by using a metallic fuel, pool-type containment, and appropriately sized thermal power. PRISM eliminates many of the safety systems required in loop-type plants by utilizing the pool-type design. By virtue of these design choices, the PRISM is able to achieve reactor shutdown, decay heat removal, and postaccident containment cooling completely via passive systems.^{52,53}

IV. SUMMARY

The ARC fully recycles all of the usable isotopes in UNF. The NFRC separates UNF into uranium and transuranics, which is then fabricated into PRISM fuel. PRISM is able to extract the energy that remains in UNF. By performing a full recycle of UNF, the waste that is discharged at the back end of the fuel cycle is composed of only the fission products. These fission products require a significantly shorter storage time in a geologic repository than the UNF that is currently discharged from reactors.^{6,7,22}

The PRISM achieves a high degree of safety via a pool-type containment, metallic fuel, and an innovative plant design. The safety characteristics of the PRISM enable it to accommodate severe transients such as loss of primary pump power coupled with the loss of all cooling by the intermediate heat transport loop without a reactor scram.⁵³

The passive safety systems and modular design of PRISM lead to improved plant economics. By fabricating PRISM modules in a factory environment, the quality of components can be improved and construction/fabrication can be performed in parallel. The shortened construction schedule and improved fabrication quality result in an economic design that is competitive with current LWRs (Ref. 48).

The PRISM design builds upon decades of experience from EBR-II, ALMR, and GE-funded programs. It is the commercial culmination of the IFR concept where UNF and uranium are completely used in an SFR. PRISM is a small modular reactor that presents an integrated solution to the nuclear waste problem.

REFERENCES

1. "EBR-I Fact Sheet," 06-GA50269, Idaho National Laboratory (2006).
2. L. KOCH, "EBR-II Experimental Breeder Reactor-II," Argonne National Laboratory (1987).
3. E. L. GLUEKLER, "U.S. Advanced Liquid Metal Reactor (ALMR)," *Prog. Nucl. Energy*, **31**, 43 (1997).
4. R. C. BERGLUND and R. B. TUPPER, "An Overview of Development Progress on PRISM: The Plant Design Concept for the U.S. Advanced Liquid Metal Reactor Program," *Proc. Pacific Basin Nuclear Conf.*, Taipei, China, April 1992.
5. D. J. HILL, "Global Nuclear Energy Partnership Technology Development Plan," GNEP-TECH-TR-PP 2007, Idaho National Laboratory (2007).
6. C. L. COCKEY, T. WU, A. J. LIPPS, and R. N. HILL, "Higher Actinide Transmutation in the ALMR," *Proc. Global '93, Future Nuclear Systems: Fuel Cycles and Waste Disposal Options*, September 1993.
7. R. A. WIGELAND, T. H. BAUER, T. H. FANNING, and E. E. MORRIS, "Separations and Transmutation Criteria to Improve Utilization of a Geologic Repository," *Nucl. Technol.*, **154**, 95 (2006).
8. D. C. WADE and Y. I. CHANG, "The Integral Fast Reactor Concept: Physics of Operation and Safety," *Nucl. Sci. Eng.*, **100**, 507 (1988).
9. C. E. BOARDMAN, C. S. EHRMAN, C. HESS, M. OCKER, and M. THOMPSON, "Integrating ALWR and ALMR Fuel Cycles," *Proc. 4th Int. Conf. Nuclear Engineering (ICONE-4)*, New Orleans, Louisiana, March 10–14, 1996.

10. COMMITTEE ON ELECTROMETALLURGICAL TECHNIQUES FOR DOE SPENT FUEL TREATMENT, *Electrometallurgical Techniques for DOE Spent Fuel Treatment: Final Report*, National Academy Press, Washington, D.C. (2000).
11. W. H. HANNUM, D. C. WADE, H. F. McFARLANE, and R. N. HILL, "Nonproliferation and Safeguards Aspects of the IFR," *Prog. Nucl. Energy*, **31**, 217 (1997).
12. C. S. EHRMAN and C. E. BOARDMAN, "System Considerations for Actinide Recycle in Fast Reactors," *Proc. Global '95 Fuel Cycle Conference*, Versailles, France, September 1995.
13. C. S. EHRMAN, C. HESS, M. OCKER, and D. WADE-KAMPER, "Design Consideration for a Pyroprocess Recycle Facility," *Proc. Global '95 Fuel Cycle Conference*, Versailles, France, September 1995.
14. L. N. SALERNO, R. C. BERGLUND, G. L. GYOUREY, F. E. TIPPETS, and P. M. TSCHAMPER, "PRISM Concept, Modular LMR Reactors," *Nucl. Eng. Des.*, **109**, 79 (1988).
15. D. T. INGERSOLL, "Deliberately Small Reactors and the Second Nuclear Era," *Prog. Nucl. Energy*, **51**, 589 (2009).
16. C. E. BOARDMAN, A. E. DUBBERLEY, D. G. CARROLL, M. HUI, A. W. FANNING, and W. KWANT, "A Description of the S-PRISM Plant," *Proc. 8th Int. Conf. Nuclear Engineering (ICONE-8)*, Baltimore, Maryland, April 2–6, 2000.
17. W. KWANT and C. E. BOARDMAN, "PRISM—Liquid Metal Cooled Reactor Plant Design and Performance," *Nucl. Eng. Des.*, **136**, 111 (1992).
18. C. E. BOARDMAN, A. E. DUBBERLEY, and M. HUI, "Optimizing the Size of the S-PRISM Reactor," *Proc. 8th Int. Conf. Nuclear Engineering (ICONE-8)*, Baltimore, Maryland, April 2–6, 2000.
19. A. E. DUBBERLEY, C. E. BOARDMAN, K. YOSHIDA, and T. WU, "S-PRISM Oxide and Metal Fuel Cord Designs," *Proc. 8th Int. Conf. Nuclear Engineering (ICONE-8)*, Baltimore, Maryland, April 2–6, 2000.
20. A. E. DUBBERLEY, T. WU, and S. KUBO, "S-PRISM High Burnup Metal-Fuel Core Design," *Proc. Int. Conf. Advancement of Nuclear Power Plants (ICAPP '03)*, Cordoba, Spain, May 4–7, 2003.
21. J. E. QUINN, P. M. MAGEE, M. L. THOMPSON, and T. WU, "ALMR Fuel Cycle Flexibility," *Proc. American Power Conf.*, 1993.
22. A. E. DUBBERLEY, C. E. BOARDMAN, D. G. CARROLL, C. EHRMAN, and C. E. WALTER, "S-PRISM Fuel Cycle Study," *Proc. Int. Conf. Advancement of Nuclear Power Plants (ICAPP '03)*, Cordoba, Spain, May 4–7, 2003.
23. D. C. CRAWFORD, D. L. PORTER, and S. L. HAYES, "Fuels for Sodium-Cooled Fast Reactors: US Perspective," *J. Nucl. Mater.*, **371**, 202 (2007).
24. G. L. HOFMAN, L. C. WATERS, and T. H. BAUER, "Metallic Fast Reactor Fuels," *Prog. Nucl. Energy*, **31**, 83 (1997).
25. D. E. BURKES, R. S. FIELDING, D. L. PORTER, D. C. CRAWFORD, and M. K. MEYER, "A US Perspective on Fast Reactor Fuel Fabrication Technology and Experience, Part I: Metal Fuels and Assembly Design," *J. Nucl. Mater.*, **389**, 458 (2009).
26. W. J. CARMACK et al. "Metallic Fuels for Advanced Reactors," *J. Nucl. Mater.*, **392**, 139 (2009).
27. "Design Data, Part 1: Structural Materials, Group 1: High Alloy Steels, Section 10—HT-9 Steel," *Nuclear Systems Material Handbook*, Vol. 1, Rev. 3, TID26666, Hanford Engineering Development Laboratory (1976).
28. D. S. GELLES, "Development of Martensitic Steels for High Neutron Damage Applications," *J. Nucl. Mater.*, **239**, 99 (1996).
29. R. L. KLUEH and A. T. NELSON, "Ferritic/Martensitic Steels for Next-Generation Reactors," *J. Nucl. Mater.*, **371**, 37 (2007).
30. A. E. DUBBERLEY, C. E. BOARDMAN, R. E. GAMBLE, M. M. HUI, A. J. LIPPS, and T. WU, "Transient Performance of S-PRISM," *Proc. 9th Int. Conf. Nuclear Engineering (ICONE-9)*, Nice, France, April 8–12, 2001.
31. G. L. GYOUREY, R. W. HARDY, and P. M. MAGEE, "Safety and Licensing of the PRISM Liquid Metal Cooled Reactor," *Nucl. Eng. Des.*, **137**, 181 (1992).
32. G. C. SLOVIK, G. J. VAN TUYLE, and S. SANDS, "Assessment of PRISM Response to Loss of Flow Events," BNL-NUREG-47818, *Proc. Int. Conf. Design and Safety of Advanced Nuclear Power Plants*, Tokyo, Japan, October 1992.
33. G. C. SLOVIK and G. J. VAN TUYLE, "Analysis of Unscrammed Events in PRISM," BNL-NUREG-46344, Brookhaven National Laboratory (1990).
34. G. C. SLOVIK and G. J. VAN TUYLE, "Analysis of Postulated Events for the Revised ALMR/PRISM Design," BNL-NUREG-46429, *Proc. Nuclear Regulatory Commission Water Reactor Safety Information Mtg.*, Bethesda, Maryland, October 1991.
35. H. P. PLANCHON, R. M. SINGER, D. MOHR, E. E. FELDMAN, L. K. CHANG, and P. R. BETTEN, "The Experimental Breeder Reactor II Inherent Shutdown and Heat Removal Tests—Results and Analysis," *Nucl. Eng. Des.*, **91**, 287 (1986).
36. C. E. LAHM, J. F. KOENIG, P. R. BETTEN, J. H. BOTTCHEER, W. K. LEHTO, and B. R. SEIDEL, "EBR-II Driver Fuel Qualification for Loss-of-Flow and Loss-of-Heat-Sink Tests Without Scram," *Nucl. Eng. Des.*, **101**, 25 (1987).
37. D. MOHR, L. K. CHANG, E. E. FELDMAN, P. R. BETTEN, and H. P. PLANCHON, "Loss-of-Primary-Flow-Without-Scram Tests: Pretest Predictions and Preliminary Results," *Nucl. Eng. Des.*, **101**, 45 (1987).
38. W. K. LEHTO, R. M. FRYER, E. M. DEAN, J. F. KOENIG, L. K. CHANG, D. MOHR, and E. E. FELDMAN, "Safety

Analysis from the Loss-of-Flow and Loss-of-Heat Sink Without Scram Tests in EBR-II," *Nucl. Eng. Des.*, **101**, 35 (1987).

39. T. H. BAUER, A. E. WRIGHT, W. R. ROBINSON, J. W. HOLLAND, and E. A. RHODES, "Behavior of Modern Metallic Fuel in TREAT Transient Overpower Tests," *Nucl. Technol.*, **92**, 325 (1990).

40. E. P. LOEWEN and C. E. BOARDMAN, "Selection of the Reference Steam Generator for the Advanced Liquid Metal Reactor," *Proc. Global '07: Advanced Nuclear Fuel Cycles and Systems*, Boise, Idaho, September 9–13, 2007, American Nuclear Society.

41. C. E. BOARDMAN and M. HUI, "A Competitive Integral Fast Reactor with Enhanced Diversion Resistance (S-PRISM)," *Proc. Int. Conf. Future Nuclear Systems (GLOBAL-99)*, Jackson Hole, Wyoming, August 29–September 3, 1999.

42. G. J. VAN TUYLE, "Simplified Analysis of PRISM RVACS Performance Without Linear Spill-Over," BNL-NUREG-44501, *Proc. Int. Topl. Mtg. Fast Reactor Safety*, Snowbird, Utah, August 1990.

43. C. E. BOARDMAN, A. E. DUBBERLEY, M. HUI, and K. IWASHIGE, "Containment Performance of S-PRISM Under Severe BDB Conditions," *Proc. 9th Int. Conf. Nuclear Engineering (ICONE-9)*, Nice, France, April 8–12, 2001.

44. E. L. GLUEKLER, C. C. BIGELOW, V. DEVITA, J. M. KELLY, R. W. SEIDENSTICKER, and F. F. TAJIRIAN, "Seismic Isolation Development for the US Advanced Liquid-Metal Reactor Program," *Nucl. Eng. Des.*, **127**, 295 (1991).

45. E. L. GLUEKLER, "Status of Reactor Seismic Isolation Technology Development in the USA and Summary of IAEA Specialists Meeting," *Proc. Int. Post-SMIRT Conf. Seminar on Isolation Energy Dissipation and Control of Vibration of Structures*, Napoli, Capri, August 1993.

46. "Global Nuclear Energy Partnership Business Development Plan," U.S. Department of Energy Report, GE Hitachi Nuclear Energy (2008).

47. E. P. LOEWEN, J. BOAZ, E. SAITO, and C. E. BOARDMAN, "Commercialization of the Global Nuclear Energy Partnership (GNEP)," *Proc. 15th Int. Conf. Nuclear Engineering (ICONE-15)*, Nagoya, Japan, April 2007.

48. "Global Nuclear Energy Partnership Advanced Recycling Center 2008 Cost & Schedule Report," U.S. Department of Energy Report, GE Hitachi Nuclear Energy (2008).

49. C. E. BOARDMAN, M. HUI, D. G. CARROLL, and A. E. DUBBERLEY, "Economic Assessment of S-PRISM Including Development and Generating Costs," *Proc. 9th Int. Conf. Nuclear Engineering (ICONE-9)*, Nice, France, April 8–12, 2001.

50. C. E. BOARDMAN, D. CARROLL, and M. HUI, "A Fast Track Approach to Commercializing the Sodium Cooled Fast Reactor," *Proc. 7th Int. Conf. Nuclear Engineering (ICONE-7)*, Tokyo, Japan, April 10–23, 1999.

51. IEEE Std. 323-2003, "Qualifying Class 1E Equipment for Nuclear Power Generating Stations," Institute of Electrical and Electronics Engineers (2003).

52. A. E. DUBBERLEY, C. E. BOARDMAN, A. J. LIPPS, and T. WU, "S-PRISM Metal Core Margins to Severe Core Damage," *Proc. 8th Int. Conf. Nuclear Engineering (ICONE-8)*, Baltimore, Maryland, April 2–6, 2000.

53. K. A. EL-SHEIKH and D. HAHN, "Effectiveness of Natural Phenomena in Reducing the Source Term and Consequences of Severe Accidents in the ALMR," *Proc. 3rd Int. Conf. Nuclear Engineering (ICONE-3)*, Kyoto, Japan, April 17–23, 1995.